

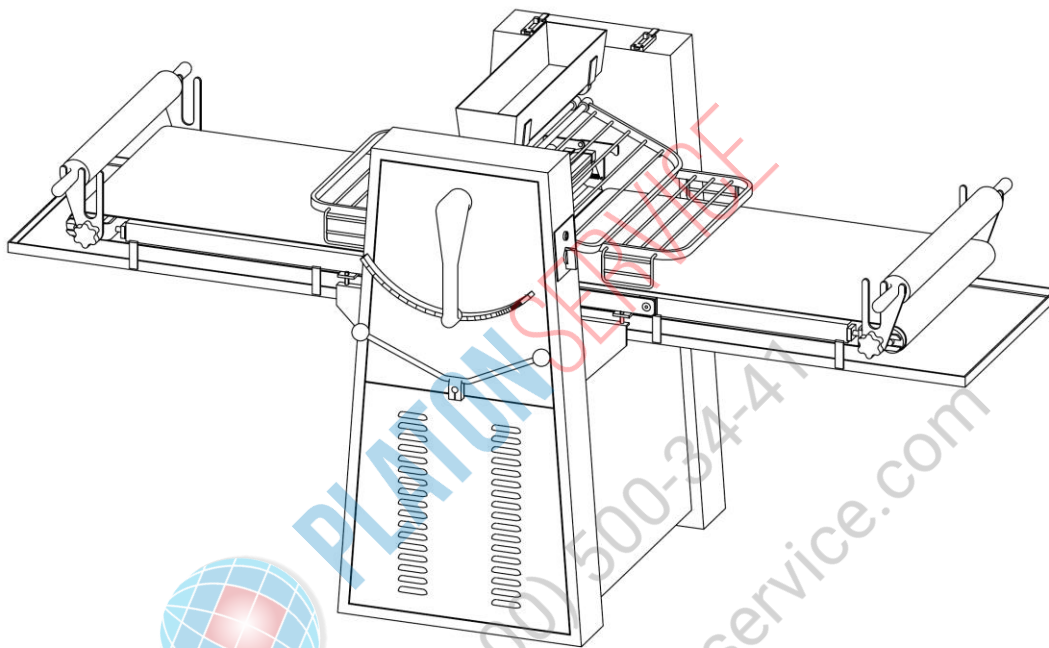

Forni e Macchine • Ovens and Machines

**DR. ZANOLLI s.r.l.**  
Via Casa Quindici, 22  
37066 Caselle di Sommacampagna  
(Verona) Italy  
Tel +39 045 8581500 (r.a.)  
Fax +39 045 8581455  
Web: [www.zanolli.it](http://www.zanolli.it) • e-mail: [zanolli@zanolli.it](mailto:zanolli@zanolli.it)



# SIRIO 500-600

**Manuale di installazione, uso e manutenzione**  
**Manual for installation, use and maintenance**  
***Manual de instalación, uso y mantención***  
***Notice d'installation, d'utilisation et d'entretien***  
**INSTALLATIONS-, BEDIENUNGS- UND INSTANDHALTUNGSHANDBUCH**



**PLATON**SERVICE

8 (800) 500-34-47

[www.platonservice.com](http://www.platonservice.com)

## INDEX

<b>Chapter 1 General information .....</b>	<b>1</b>
1.1 Documentation supplied .....	1
1.2 This manual.....	1
1.3 Information property rights.....	1
1.4 Conventions .....	2
1.5 Manufacturer identification details.....	3
1.6 Machine identification details.....	3
1.7 EC declaration of conformity .....	3
1.8 Guarantee .....	4
1.9 Use of the manual .....	5
1.10 Description of the machine .....	6
1.11 Qualifications of personnel.....	9
1.12 Safeguards.....	10
1.13 Hazardous areas and residual risks .....	12
<b>Chapter 2 Machine Specifications .....</b>	<b>13</b>
2.1 Technical specifications.....	13
<b>Chapter 3 Operator Interface.....</b>	<b>16</b>
3.1 Controls.....	16
<b>Chapter 4 Installation.....</b>	<b>17</b>
4.1 Hazardous areas and residual risks during installation.....	17
4.2 Qualifications of operator .....	17
4.3 Transport.....	18
4.4 Preliminary operations.....	20
4.5 Installation .....	21
4.6 Preparation for start-up.....	21
4.7 Testing .....	23
<b>Chapter 5 Machine operation .....</b>	<b>24</b>
5.1 Qualifications of operator .....	24
5.2 Work station.....	24
5.3 Operating modes .....	25
5.4 Machine switching on.....	25
5.5 Tooling, adjustments and setting up .....	25
5.6 Starting.....	25
5.7 Routine stopping of machine .....	25
5.8 Emergency stop.....	26
5.9 Starting the machine again after a manual emergency stop.....	26
5.10 Switching off the machine .....	26
<b>Chapter 6 Maintenance .....</b>	<b>27</b>
6.1 Routine maintenance.....	27

---

6.2	Scheduled servicing.....	29
<b>Chapter 7</b>	<b>Machine scrapping .....</b>	<b>30</b>
7.1	Qualifications of operator.....	30
7.2	Disconnecting the machine .....	30
7.3	Disconnection procedure.....	30
7.4	Residual risks after machine disconnection .....	31
<b>Chapter 8</b>	<b>List of attached documentation.....</b>	<b>32</b>



**PLATON SERVICE**

8 (800) 500-34-41

[www.platonservice.com](http://www.platonservice.com)

## Chapter 1 *General information*

---

---

### 1.1 **Documentation supplied**

- Instruction manual (this booklet)
- Spare parts catalogue.

#### ***Other documentation***

- Wiring diagrams

---

### 1.2 **This manual**

#### ***Details about manual***

*Instruction manual:* **DOUGH SHEETER**

Model: **SF. 500 - SF. 600**

- Edition: 1.0
- Year and month of printing: Aprile 2005

#### ***Addressees***

- Carrier.
- Installer.
- End user.
- Maintenance engineer.

---

### 1.3 **Information property rights**

This manual contains copyright information. All rights are reserved.

No part of this manual can be reproduced or photocopied without the prior written permission of the manufacturer. Permission to use this documentation has only been given to the customer to whom the manual has been supplied as part of the machine's equipment and only for the purpose of installation, operation and maintenance of the machine to which the manual refers.

The manufacturer declares that all the information contained herein is in accordance with the technical and safety specifications of the machine to which the manual refers. The

manufacturer will not be held responsible for direct or indirect damage or injury to persons, objects or animals resulting from the use of this documentation or the machine in non-standard conditions.

The manufacturer reserves the right to introduce technical modifications or improvements both to the documentation and to the machines without prior notice. Modifications and improvements may also concern other machines of the same model described in this manual, but which have a different serial number. The information contained herein refers in particular to the machine specified in *1.6 Machine identification details* a pag. 3.

---

## 1.4 Conventions

### *Linguistic conventions*

- On the left, on the right : when speaking of such, we refer to the operator's position when facing the control panel.
- Qualified workers : all those persons who thanks to their training, experience, education as well as their knowledge of standards, regulations, safety precautions and operation conditions, have been authorised by the person in charge of plant safety to carry out any necessary action and are capable of identifying and avoiding possible danger.

### *Printing conventions*

*Text in italics* : this indicates the title of a chapter, a section, a subsection, a paragraph, a table or a drawing in this manual or other reference document.

PSE : Personal Safety Equipment.

Ⓝ where N represents a generic number (e.g. ③): Rappresentazione simbolica di un dispositivo di comando o di segnalazione (p.es. pulsanti, selettori e spie luminose).

Ⓛ where L represents a generic letter (e.g. ⓑ): symbolic representation of a part of the machine.

---

**NOTE** Notes contain important information and are highlighted separately from the text to which they refer.

---



---

**BEWARE** Beware indications describe the procedures the partial or total non-observance of which can cause damage to the machine or to devices connected to it.

---



---

**DANGER** Danger indications describe the procedures the partial or total non-observance of which can injure or harm the operator's health.

---

---

## 1.5 Manufacturer identification details

---

---

---

---

Tel.  
Fax

---

E mail:

---

## 1.6 Machine identification details

Type: Dough Sheeter

Model: SF. 500 - SF. 600

Serial no.: \_\_\_\_\_

Year of manufacture: \_\_\_\_\_

Volt: \_\_\_\_\_

Frequency Hz: \_\_\_\_\_

No. of phases: \_\_\_\_\_

Total Kw: \_\_\_\_\_

Ampère: \_\_\_\_\_

Weight Kg: \_\_\_\_\_

---

## 1.7 EC declaration of conformity

The CE declaration is attached herewith as a separate file.

## 1.8 Guarantee

### General conditions

1. This machine (with appropriate serial number) is guaranteed for 12 months after the date of actual delivery.  
This guarantee is, however, subject to the claim being made by means of registered letter, within 8 days after discovery of any faults or defects providing that prior confirmation and acknowledgement is obtained from the manufacturer.
2. The guarantee covers the replacement or repair of the faulty part (component, machine or part of the machine) but does not cover the cost of dismantlement, re-assembly or shipping.
3. The replacement of any part does not bring about the renewal of the guarantee period for the entire machine, unless the entire machine is replaced.  
Therefore, in no circumstances shall the manufacturer be liable for compensation of whatever type and the purchaser shall relinquish any claim for damage, loss or expense, even to third parties, arising from machine stoppage.
4. This guarantee does not cover the electrical parts and the parts subject to normal wear and tear or deterioration due to external atmospheric or environmental agents nor does it cover any defects arising from the failure to carry out maintenance or insufficient or incorrect maintenance, nor does it cover use by unqualified personnel, misuse, abuse or improper use, unauthorised alterations or repairs or tampering of any kind.
5. The validity of the guarantee is subject to the performance of correct maintenance as described in *Chapter 6 Maintenance* of the instruction manual supplied with the machine.
6. The guarantee is not valid if payment conditions have not been observed.
7. As far as parts supplied by other manufacturers are concerned, said parts are guaranteed in accordance with the terms of the said manufacturer's warranty.
8. Any controversy shall be governed directly by the court of Competent Jurisdiction.

**NOTE**  In the event of repairs performed at the place of machine installation, the machine guarantee certificate must be presented to the service engineer and the guarantee is valid only if fully completed.

Special guarantee conditions will be explicitly stated in the sales contract.

### The guarantee will expire in the following cases:

- Improper machine use (see *Improper use* a pag. 6).
- Use of equipment different from the equipment specified in *Chapter 6 Maintenance*.
- Assembly of the machine in conditions different from those specified in *Chapter 4 Installation*.
- Connections which fail to comply with the specifications given in *Chapter 4 Installation*.
- Use of non-original spare parts or parts not specified by the manufacturer.



## Claiming under guarantee

### Method

Requests for spare parts or service visits under guarantee must be made to the manufacturer or to your authorised dealer as soon as possible after having encountered the defect which is covered by the *General conditions* a pag. 4.

---

**BEWARE** We recommend the use of original spare parts.

---

Always state the type, model and serial number of the machine when requesting spare parts under guarantee. This information can be found on the name plate of the machine.

---

**NOTE** Failure to comply with the instructions contained herein will release the manufacturer from any liability in the event of accidents to persons and/or objects, or machine malfunctioning.

---

### Requests for spare parts

When requesting spare parts please state the following information:

- Type of machine.
- No. of production order marked on the relevant label.
- Year of manufacture.
- Reference number of the required part which can be found on attachments spare parts given in the spare parts catalogue.

If necessary please contact:

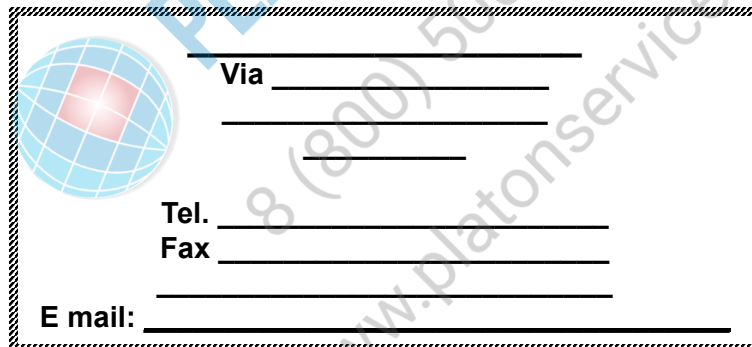

The form is enclosed in a dashed border and contains a globe icon on the left. It has the following fields:

- Via** \_\_\_\_\_
- \_\_\_\_\_
- \_\_\_\_\_
- Tel.** \_\_\_\_\_
- Fax** \_\_\_\_\_
- \_\_\_\_\_
- E mail:** \_\_\_\_\_

---

## 1.9 Use of the manual

Read the following chapters carefully: *Chapter 1 General information, Fig. 1.1 Overall view of machine, Chapter 2 Machine Specifications, Chapter 3 Operator Interface.*

Consult the relevant chapter before attempting installation, operation, maintenance or dismantlement.

---

**NOTA** This manual should be kept in good condition for the whole of the life of the machine and should be stored where it can be easily found when required. The manual should be handed over to the purchaser of the machine if this is sold to someone else.

---

---

## 1.10 Description of the machine

### ***Intended use***

#### **Intended operations**

The machine has been built and designed to sheet dough to the thickness required by the operator.

#### **Conditions of intended use**

The machine has been designed and built to operate in a closed environment, protected from atmospheric agents.

#### **Intended use of power**

The machine is driven by electric energy, which is converted into mechanical energy for the intended operations.

### ***Improper use***

Improper use means any operation not expressly stated in the *Intended use* a pag. 6, in particular:

- Operating the machine in an explosive environment.
- Operating the machine in a flammable environment.
- Washing the machine control area with jets of water.



### **Machine structure**

This section describes the main machine components and their function within the production cycle.

### **Main machine components**

The machine is composed of the following principal components:

1. Base
2. Operating controls.
3. Conveyor Belts
4. Sheeting cylinders
5. Scrapers
6. Dough thickness selection handle
7. Pastry tray

Fig. 1.1 Overall view of machine

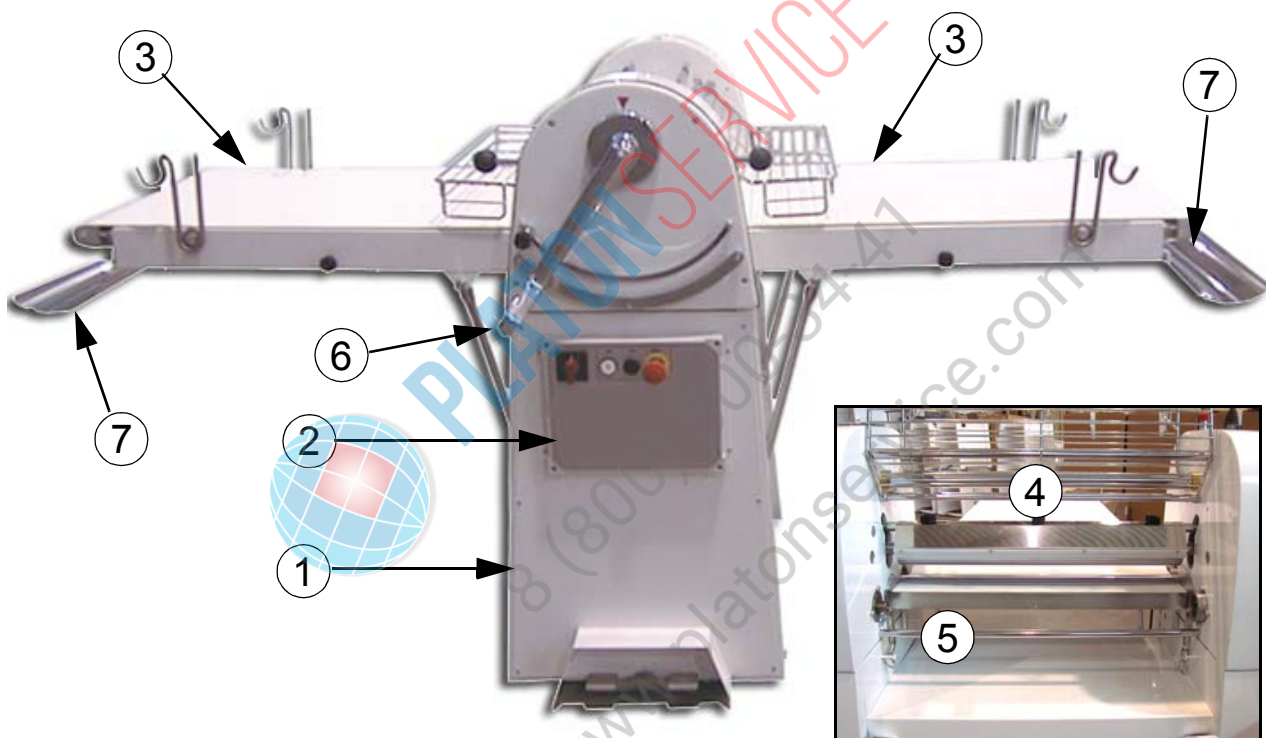

During the design and construction of this machine the manufacturer has adopted the criteria and devices needed to satisfy the essential safety requirements imposed by the Machinery Safety Directive 98/37/CE and subsequent amendments, by the Low Voltage Directive 73/23/EEC and subsequent amendments and by the Electromagnetic Compatibility Directive 89/336/EEC and subsequent amendments.

The careful analysis of risks carried out by the manufacturer has eliminated most of the risks (predicted or reasonably predictable) linked to the machine operation conditions.

The complete documentation of safety measures taken is contained in the technical brochure of the machine kept at the manufacturer.

The manufacturer strongly recommends careful observation of the instructions, procedures and recommendations contained herein as well as strict observation of the current safety regulations regarding the work environment. This also applies to the use of both the correct personal safety equipment and machine protection devices.

---

**NOTE** Do not wear loose clothing, ties, chains, or watches that could get caught in the moving parts of the machine.

---

---

**NOTE** The manufacturer will not be liable for any damage or injury to persons, animals or things caused by non-observance of the safety rules and/or recommendations given in the documentation supplied.

---



PLATON SERVICE  
8 (800) 500-3421  
www.platonservice.com

## 1.11 Qualifications of personnel

Stage in the technical life of the machine	Qualification of operator in charge
Transport	Qualified carrier informed of: <i>Fig. 1.1 Overall view of machine,</i> <i>4.3 Transport</i> a pag. 18 of this manual.
Installation	Qualified electrician and qualified mechanic informed of : <i>Fig. 1.1 Overall view of machine,</i> <i>Chapter 2 Machine Specifications,</i> <i>Chapter 3 Operator Interface</i> <i>Chapter 4 Installation.</i>
Operation	Trained worker informed of : <i>Fig. 1.1 Overall view of machine,</i> <i>Chapter 2 Machine Specifications,</i> <i>Chapter 3 Operator Interface,</i> <i>Chapter 5 Machine operation.</i>
Maintenance	There are three different types of workers who can carry out interventions on the machine: <ul style="list-style-type: none"> <li>• <b>Mechanical maintenance engineer:</b> qualified engineer able to operate the machine in normal conditions and with the machine guards open. Able to carry out adjustments, maintenance and repairs on mechanical parts. This worker should not be assigned to electrical interventions on live parts..</li> <li>• <b>Electrician:</b> qualified engineer able to operate the machine in normal conditions and with the machine guards open. Able to carry out electrical adjustments, maintenance and repairs. This worker can be assigned to electrical interventions on live parts inside the electric control box.</li> <li>• <b>Manufacture's engineer:</b> qualified engineer put at customer's disposal by the manufacturer to carry out complicated repairing in special conditions, according to the agreements taken with the customer.</li> </ul>
Scrapping	Qualified mechanic informed of: <i>Fig. 1.1 Overall view of machine,</i> <i>Chapter 7 Machine scrapping.</i>

**NOTE** The manufacturer will not be liable for damage or injury to persons, animals or things resulting from the action of unqualified operators.

## 1.12 Safeguards

### DEFINIZIONE

*Safeguards are any safety measures which involve the application of specific technical mechanisms (guards, safety devices) to protect people from dangers which cannot be made sufficiently harmless through design.*

### Fixed and moveable guards

- All power transmission components are shielded by screw-fastened guards, in compliance (A), with the EN 953 standard.
- All moving parts are protected by the metal safety grille (B).

Fig. 1.2 Fixed and moveable guards

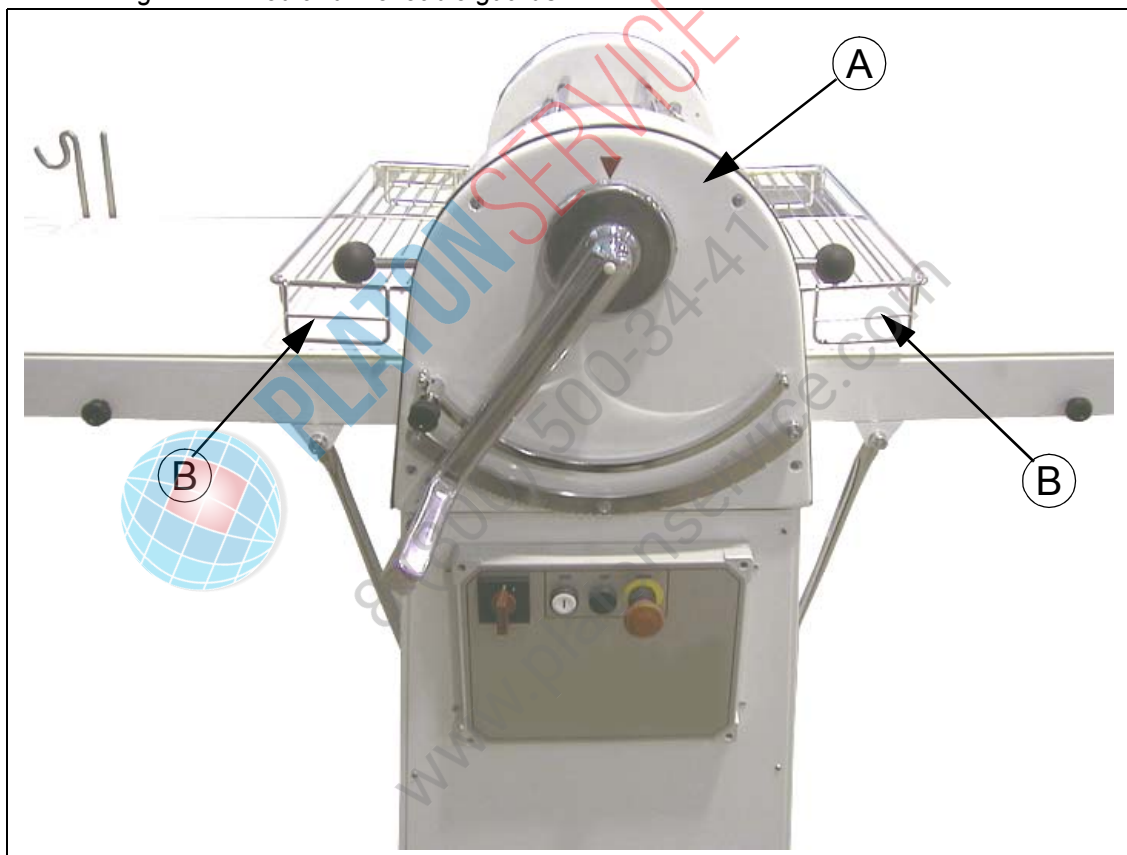

### Passive safety devices

#### DEFINIZIONE

*Passive safety devices are those devices or safeguarding techniques which eliminate or reduce potential hazards for the operator without the operator having to actively intervene.*

### Limit switch devices

The machine is equipped with two limit switch microswitches (A) and (B) (Fig. 1.3). These are energised by means of two cams (C) and (D), which are in turn fixed to the safety grille (Fig. 1.2 Fixed and moveable guards a pag. 10). If the operator raises the protection grille the cams turn and energise the relevant microswitch which controls a Machine Stoppage.

Two further microswitches (E) and (F), are installed on the machine which are energised by two blocks which adjust pastry thickness.

Fig. 1.3 Microswitch

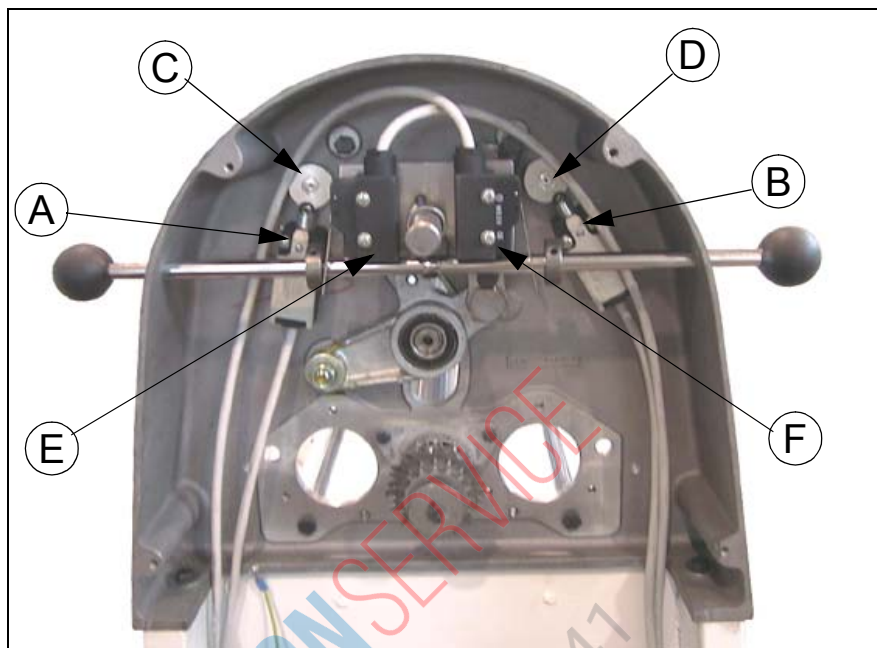

### Active safety devices

#### DEFINIZIONE

*Active safety devices are those devices or safeguarding techniques which eliminate or reduce potential hazards and which require active and conscious intervention by the operator in order to activate their accident preventative action.*

### Emergency stop

The emergency button is located on the main control panel of the machine and allows the operator to stop the machine in an emergency.

Fig. 1.4 Emergency button

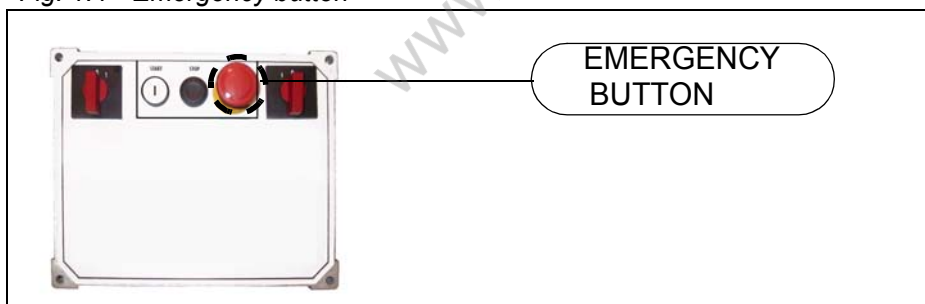

### Safeguarding

- The electrical equipment offers protection against personal injury caused by electrical discharge due to direct and indirect contact in compliance with the CEI EN 60204-1 standard.
- All the electrical power parts and those with dangerous voltage are contained in the electrical box protected to IP54, in compliance with the CEI EN 60204-1 standard. The control and power supply voltages for all the accessible parts are 12 and 24V; moreover



both these lines are protected against short-circuiting and accidental contact to earth.

---

**DANGER** Tampering with safety devices creates hazards for the machine operators and other exposed persons.

---



---

**NOTE** The manufacturer will not be liable for injury or damage to people, animals or things caused by tampering with the machine's safety devices.

---

## 1.13 Hazardous areas and residual risks

### DEFINIZIONE

*A hazardous area is any area inside or in the vicinity of the machine which would constitute a risk for the health and safety of an exposed person.*

This manual indicates all the procedures during which residual risks for the operator are present. The residual risks can be eliminated by carefully following the procedures indicated in this manual and by using the recommended personal safety equipment.



Protective gloves must be worn.



Protective footwear must be worn.

**Handling area of the packed or unpacked machine.** The following risks are present here:

- Impact hazard for operator.
- Crushing hazard.

*The following PSE must be used by the operator:*



- Protective footwear.
- Protective gloves.

---

**NOTE** The manufacturer will not be liable for damage or injury to persons, animals or things resulting from non-compliance with the safety rules or from the recommended PSE not being worn.

---



## Chapter 2 *Machine Specifications*

### 2.1 Technical specifications

#### *Dimensions and weight of the machine*

Model SF. 500	With tables of 700 mm	With tables of 1000 mm	With tables of 1200 mm
Machine operating (machine open) (mm)	1800x1100x880	2320x1100x880	2800x1100x880
Machine not operating (mm)	560x1460x880	560x1700x880	560x1920x880
Weight (kg)	148	155	162

Model SF. 600	With tables of 1000 mm	With tables of 1200 mm	With tables of 1500 mm
Machine operating (machine open) (mm)	2340x1160x1010	2780x1160x1010	3380x1160x1010
Machine not operating (mm)	640x1750x1010	640x1960x1010	640x2250x1010
Weight (kg)	205	215	230

#### *Other technical characteristics*

SF. 500	Roller Lengths (mm).	500
	Cylinder Diameter (mm)	60
	Cylinder Range (mm)	0/35

SF. 600	Roller Lengths (mm).	600
	Cylinder Diameter (mm)	70
	Cylinder Range (mm)	40

## Power Supply Details

### Standard Electrical Installation

#### Electrical Power

Tension	400 $\pm$ 10% V three-phase
Frequency	50 $\pm$ 1% Hz
Power of Electrical motor	1,5 CV.

#### Tolerances of the electrical power supply

##### Voltage

Running voltage:  $\pm$ 10% of rated voltage.

##### Frequency

$\pm$ 1% of rated frequency in continuous running

$\pm$ 2% of rated frequency for a short working period.

##### Harmonics

The harmonic distortion, for the sum of harmonics from the second to the fifth, should not exceed 10% of the total voltage with effective value between live conductors. A further distortion of 2% for the sum of the harmonics from the sixth to the thirtieth on the total effective value between live conductors is tolerated.

##### Unbalance of the three-phase power supply voltage.

Neither the inverse sequence component, nor the zero sequence component should exceed 2% of the direct sequence component of the voltage.

##### Voltage pulses.

These must not last longer than 1.5 ms with a rise/descent time between 500 ns and 500 ms and a peak value not greater than 200% of the effective value of the rated power supply voltage.

##### Breaks in voltage.

The power supply should not be broken or the voltage must not drop to zero for more than 3 ms, regardless of the instant of the supply wave. More than 1 s should elapse between two consecutive breaks.

##### Voltage drops.

Voltage drops should not exceed 20% of the peak voltage of the power supply for more than 1 cycle. More than 1 s should elapse between two consecutive voltage drops.

##### Liability

##### NOTA

The manufacturer will not be liable for defects, breakdowns or malfunctioning arising from the non-compliance with the power supply values stated.

## Other Technical Details

### Scraper.

In case of movement it is possible to reposition the scraper:

- remove the spring (A) from the fixing screw (B)
- unscrew the screw (C)
- adjust the scraper (D)
- tighten the screw (C)
- re hook the spring (A) to the screw (B).

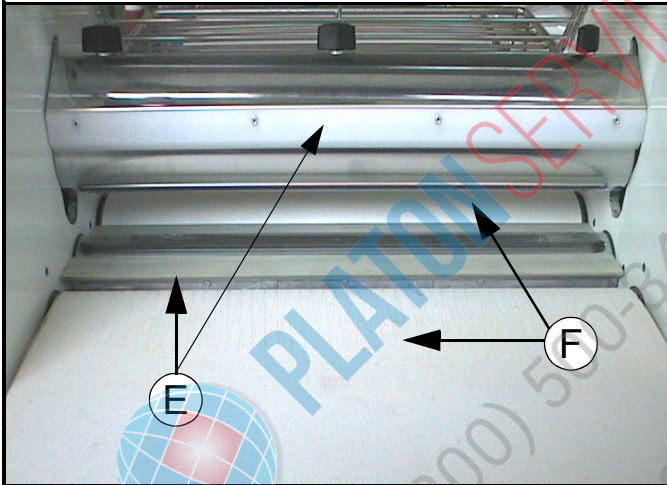
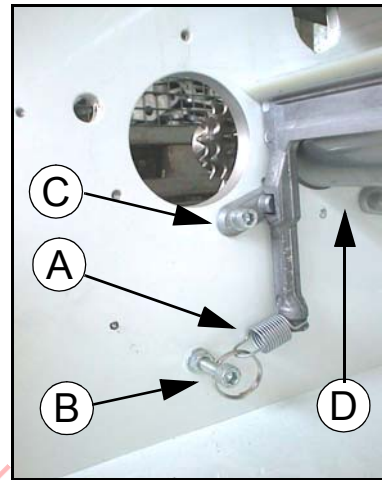

The scraper (E) facilitates the movement of the dough from one conveyor belt to the other (F).

## Chapter 3 *Operator Interface*

### 3.1 Controls

#### Controls

Symbol	Description	Functions controlled
①	Red mushroom button on a yellow background.	<b>EMERGENCY</b> button. When pressed, this stops the machine completely by cutting off the voltage to the electric circuits.
②	Main switch	If enabled energises the control board and drives
③	<b>START</b> push button	The motor starts to rotate when this button is pressed
④	<b>STOP</b> push button	The motor stops when this button is pressed, but it is not cut off from the power supply.
⑤	Pole change switch	Solo su richiesta per macchine a due velocità.
⑥	Manual control lever for reverse motion.	This lever reverses the direction of the conveyors and sheeting rollers.
⑦	Sheet thickness selection lever.	Rotate the lever to increase or decrease the distance between the sheeting rollers.

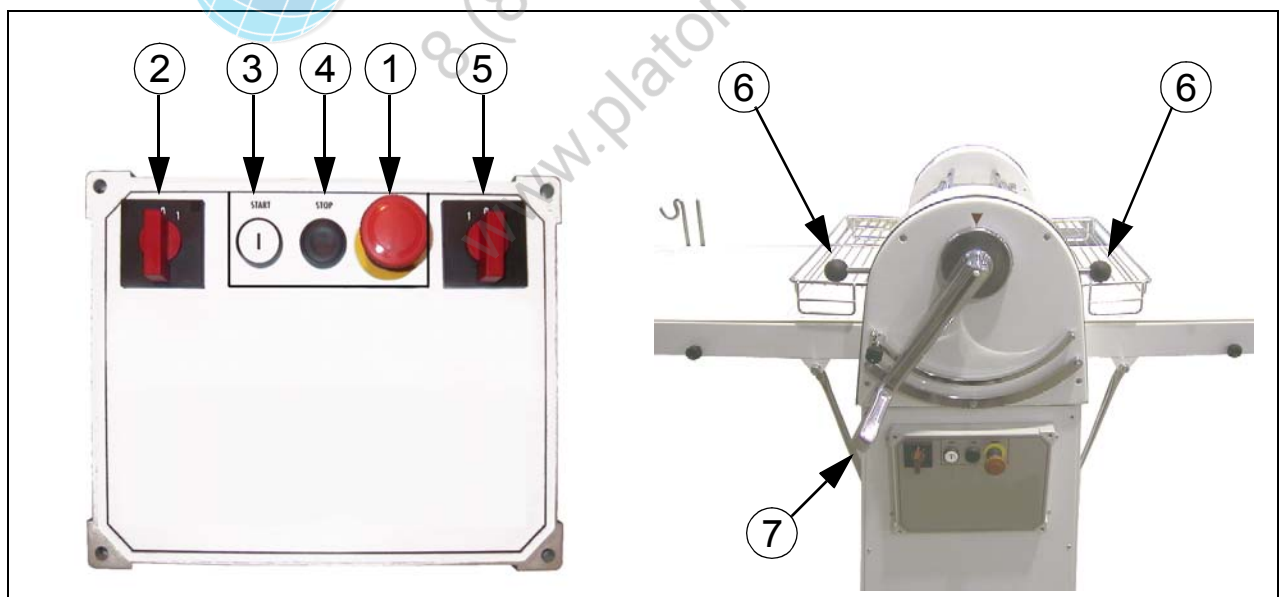

## Chapter 4 *Installation*

---

---

**NOTE** When reading this chapter refer to the pictures of the control panels given in *Chapter 3 Operator Interface*.

---

---

### 4.1 Hazardous areas and residual risks during installation



Protective gloves must be worn.



Protective footwear must be worn.

**Handling area of the packed or unpacked machine.** The following risks are present here:

- Impact hazard for operator.
- Crushing hazard.

*The following PSE must be used by the operator:*



- Protective footwear.
- Protective gloves.

---

**DANGER** When unloading, hoisting and handling the machine, personnel must wear the appropriate PSE, such as gloves, boots, helmet and use the appropriate tools.

---

---

### 4.2 Qualifications of operator

The installation of the machine should only be carried out by trained, qualified and authorised personnel after having read and understood the information given in this manual.

## 4.3 Transport

The instructions given in this section should be carefully followed when transporting the machine. This operation may include the following situations:

- Storage of the machine.
- Initial installation of the machine.
- Re-location of the machine.

### **Transport conditions**

The machine and its equipment can be transported in the following ways, according to the customer's requirements:

- **Carton on pallet**
- **Wooden crate**
- **Pallet**
- **In each of these cases, before transport or handling, the various accessories must be packed and fastened to the machine.**

---

**NOTE** Follow standard precautions to avoid collisions and tipping over.

---

### **Symbols on the machine packing**

The following symbols are shown on the machine packing:

- Handle with care.
- Centre of gravity.
- Hooking point.
- Store in a dry place.
- This side up.
- CE marking.

### **Lifting**

---

**DANGER**

- It is forbidden to climb onto the machine and/or its packing or stop and/or pass under the machine during handling.
- Access to the lifting and handling area is denied to all personnel except those directly involved in the operations.
- All operators should remain at a safe distance in order to avoid being hit by the machine or any of its parts which may accidentally fall.
- Before starting the lifting operations the whole of the machine handling area, including the parking area for the means of transport and the machine installation area, should be identified and inspected in order to detect any potentially hazardous areas.
- Use a bridge crane, a crane or a forklift truck with adequate lifting capacity. The use of inadequate lifting equipment may cause damage to the machine or injury to personnel.

Check that the hoisting cables or ropes are equipped with bell and have the label which contains all the manufacturer's details and that the lifting capacity is clearly stated.

---

**DANGER**

- Check the cables or ropes before each lifting operation. Do not use these if they are damaged or worn or have broken strands or wires.
- Never twist or knot ropes or cables. Always follow the instructions supplied by the manufacturer.
- Follow the same precautions when using chains or belts.

**Lifting and handling the packed machine**

Fig. 4.1 Lifting and handling the packed machine

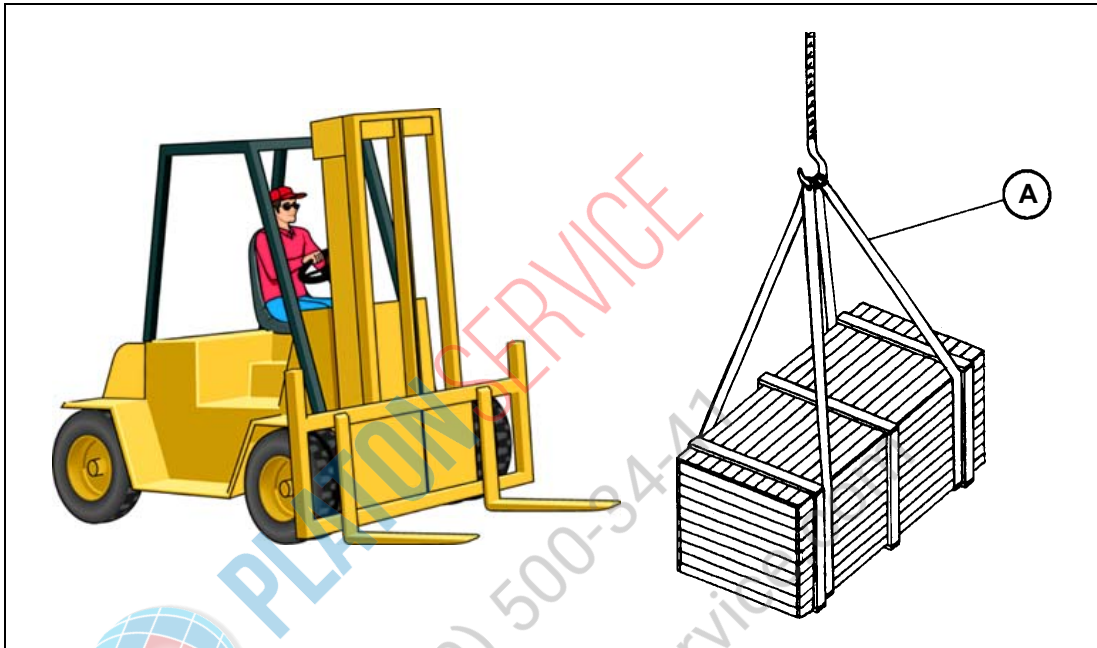

**Wooden crate on the vehicle platform**

The case **must be** unloaded from the transporting vehicle using the lifting equipment as described below:

1. Insert the cables or ropes (A) under the box pallet and attach them to the hook of the crane/bridge crane.
2. Lift the box pallet just enough to be able to unload it.
3. Position the box pallet in the planned position.

**Wooden crate on the ground**

The case must be handled using the lifting equipment as described below:

1. Insert the cables or ropes (A) under the box pallet and attach them to the hook of the crane/bridge crane.
2. Lift the box pallet just enough to be able to handle it.
3. Position the box pallet in the planned position for unpacking.

**Equipment for hoisting and handling the packed machine**

The following equipment is required to hoist the machine :

- Crane / bridge crane with adequate lifting capacity.
- Lift truck
- Rope Ø 20 type "RR" with textile core.
- Safety hook type BK-10.
- Lifting brackets.



---

**ATTENTION** If the machine has been damaged during transport, inform the manufacturer immediately. The manufacturer should also be informed if there are differences between the "Packing list" and the goods actually delivered.

---

---

**ATTENTION** The machine and its equipment should be protected from external atmospheric agents. In particular water and damp can cause certain machine components to rust, causing irreversible damage.

---

---

## 4.4 Preliminary operations

### ***Check if the machine has been damaged during transport***

Check the condition of the machine taking a close look at the outside and the inside. Any deformation of the visible parts indicates that the machine has been hit by something during transport. This could lead to malfunctioning.

Check the tightening of screws, bolts and fittings.

### ***If damage has occurred:***

Damage caused by transport should be attributed to the carrier and the manufacturer or its agent should be informed immediately of the situation.

### ***Cleaning the machine***

- Remove the dust and dirt deposited on the surface during transport.
- Carefully clean and dry each part (varnished or unvarnished) using soft, clean, dry cloths.

---

**ATTENTION** It is strictly forbidden to climb onto the box pallets and/or to stow them one on top of the other.

---

- Should the box pallets remain outdoors for some time, waiting to be transported inside the building, these box pallets should be covered with adequately-sized waterproof tarpaulins.
- If storage exceeds 3 months the box pallets should be stored inside, sheltered from bad weather and protected from excessively high or low temperatures.
- If the machine is unpacked, it should be covered in order to prevent the build-up of dust and dirt.



## 4.5 Installation

### **Features of the installation site**

A suitable installation site should be chosen considering the overall dimensions of the machine supplied in 2.1 *Technical specifications* a pag. 13, and in compliance with the following rules:

- The power supply source, in compliance with the *Standard Electrical Installation* a pag. 14 should be near the installation site.
- Nothing should hinder the free movement of the operator around the machine. The machine should be situated at least 1 metre from the nearest wall or object.
- Cabinets should be accessible at all times and the doors should open wide without obstacle.
- Make sure there is sufficient space for machine operation and maintenance and also for any other additional equipment..

### **Protection against external atmospheric agents**

The machine should be installed in a covered building, shielded from direct contact with atmospheric agents.

### **Lighting**

Adequate lighting is necessary to carry out both normal operation and servicing of the machine in a safe way. The machine has no built-in lighting system.

A well-lit environment prevents hazards due to areas in shadows.

### **Acceptable environmental conditions for the installation site:**

- Temperature: from 5° C to 40 °C with the average temperature not exceeding 35°C over a period of 24 hours.
- Relative humidity: from 50% at a temperature of 40°C up to 90 % at a temperature of 20° C.

---

**NOTE** The temperatures limits have been established taking into account the electrical equipment of the machine

---

---

## 4.6 Preparation for start-up

### **Connections**

#### **Electrical connections**

Follow the instructions given below, exactly as described, for the first start up of the new automatic machine.

---

**NOTE** As soon as the machine is delivered and before pressing any button, carry out following operations.

---

1. Insert the plug in the power socket;
2. Control the direction of motion of the conveyors: verify that when the joystick is shifted to the left the conveyors move towards the left and vice versa;
3. If the rotating direction is the opposite to the direction of the joystick, simply swap over the

phase wires (L2) and (L3).

Fig. 4.2 Socket

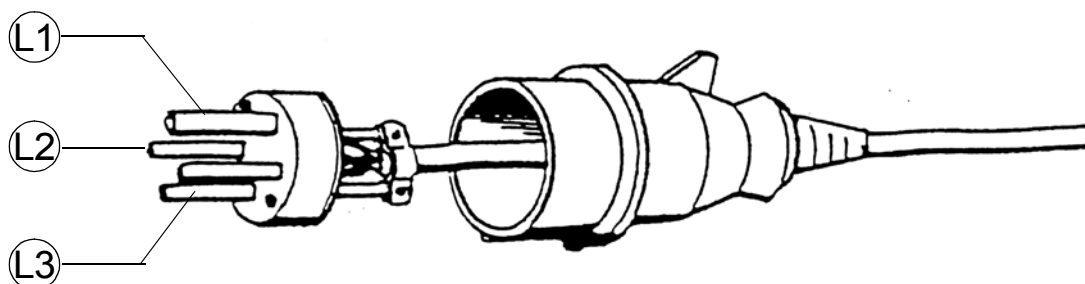

---

**DANGER** Make sure that the values of your mains electricity supply comply with the power specifications of the machine.  
Electrical hazards. Make sure the machine is adequately earthed before making any other connection to the mains power supply.

---



PLATON SERVICE  
8 (800) 500-34-41  
www.platonservice.com

## 4.7 Testing

- Before delivery the machine is tested at the manufacturer's works where the following operations are carried out:
- General setting of the machine, of the auxiliary equipment and of the installed safety devices.
- Running test to check all the adjustments carried out (correct rotation of motors, tightness of pneumatic systems, effectiveness of safety devices and of limit switches).
- Performance of test cycles under safe conditions.

### Checking the safety devices

Before starting the machine, the safety devices should be checked according to the following procedure:

1. Correct operation of the emergency stop button **①** (*Chapter 4 Installation* a pag. 17) ; while the machine is operating, press the emergency buttons: the machine should stop immediately.

---

**NOTE** If the machine does not stop immediately, the emergency buttons must be checked and/or replaced.

---

Should a problem arise, when the machine is running, for which no instructions are given in this manual, please contact the Technical After Sales Service (see *1.5 Manufacturer identification details* a pag. 3).



PLATON SERVICE  
8 (800) 500-34-47  
www.platonservice.com

## Chapter 5 *Machine operation*

---

---

**NOTE** When reading this chapter refer to the pictures of the control panels given in *Chapter 3 Operator Interface*.

---

---

### 5.1 Qualifications of operator

The machine should be operated only by trained, qualified and authorised personnel who have read and understood the information contained in this manual.

---

### 5.2 Work station

*Fig. 5.1 Work station* shows the working positions in which the operator can operate the machine safely.

The control station of the machine is located in front of the control panel. From this position the operator controls all the working parameters.

---

**NOTE** While the machine is running, access to the working area of the machine is strictly forbidden.

---

*Fig. 5.1 Work station*



## 5.3 Operating modes

The machine operates in manual mode following the instructions given in 5.6 *Starting* a pag. 25.

## 5.4 Machine switching on

To switch the machine on proceed as follows:

1. Rotate the main switch (2) installed on the front of the machine (vedi *Chapter 4 Installation* a pag. 17).

## 5.5 Tooling, adjustments and setting up

### **Adjustment warnings**

1. All adjustment, checking or cleaning operations must be carried out with the machine at a standstill and the electric control box off. The main on-off switch must be set to position O and padlocked; the pneumatic shut-off valve must be closed. **Any operation carried out while the wiring system is live can cause serious injuries.**
2. Pay special attention to the moving parts of the machine.
3. Take special care when activating the start buttons and only activate these after making sure that persons or things are in no danger.
4. If the guards or safety barriers have been removed, make sure they are correctly re-installed before using the machine again.
5. Do not rest tools or other objects on the machine, either when operating or off.

## 5.6 Starting

1. Turn the main on-off switch (2) situated on the electric control box to position "I" (vedi *Chapter 4 Installation* a pag. 17).
2. Set the sheet thickness using the lever (7) (see *Chapter 4 Installation* a pag. 17).
3. Press the start button to (3) start the motor (*Chapter 4 Installation* a pag. 17).
4. Use the lever or pedal to move the conveyor belt forward (6).
5. Adjust the sheet thickness using the lever (7).

## 5.7 Routine stopping of machine

Stopping procedure:

1. Make sure the work cycle is finished.
2. Turn the main on-off switch to position O. (2) (see *Chapter 4 Installation* a pag. 17).

---

## 5.8 Emergency stop

To stop the machine in an emergency, press the EMERGENCY button (1) (Chapter 4 Installation a pag. 17) :

- The machine stops.
- The mushroom-head button will remain blocked.

---

## 5.9 Starting the machine again after a manual emergency stop

1. Eliminate the cause of the emergency stop.
2. Release the EMERGENCY button (1) (Chapter 4 Installation a pag. 17).
3. The machine is now ready to be used again.

---

## 5.10 Switching off the machine

To switch the machine off:

1. Turn the knife-switch situated upstream from the outside power supply cable to position "O".

---

**NOTE** Always clean the machine and the working area at the end of the working cycle.

---



## Chapter 6 *Maintenance*

---

---

**DANGER** Risk of electric shock and unexpected movements during maintenance. Isolate the machine from electric and hydraulic power sources. Dissipate and/or limit residual energy (see *Chapter 5 Machine operation*).

---

---

### 6.1 Routine maintenance

Any operation that can be carried out by the user is considered routine maintenance. It includes operations of cleaning, inspection and prevention carried out to ensure safe operation of the machine.

---

**NOTA** In the event that the machine vibrates, the scrapers must be carefully checked to ensure that they have not become bent at a different angle. In the event that this should happen then the scrapers should be manually bent back to their original shape.

---

---

**ATTENTION** Keep the roller scrapers clean at all times to avoid having to perform special maintenance more often than specified in this manual.

---

#### **Qualifications of operator**

To carry routine maintenance safely, the user should first read carefully and understand the instructions and recommendations given in this section.

#### **Clean**

---

**DANGER** Cleaning operations should only be carried out with the machine switched off and disconnected from the electric and hydraulic power supplies.

---

Regular cleaning of your machine will ensure its good working order. We recommend the following:

- Clean the machine at the end of each shift.
- The cleaning of the machine keeps the most delicate parts in good working order and helps to spot any loosening of parts and any abnormal wear and tear.

**NOTE** The machine is equipped with a drawer (1), which is situated beneath the conveyor belts and allows any waste material which has been scraped to be collected. This drawer is fixed in place with a knob (2). By unscrewing the knob it is possible to clean the drawer. (Fig. 6.1 Drawer for collecting waste a pag. 28)

Fig. 6.1 Drawer for collecting waste



**BEWARE** Do not use jets of water to clean the control panels and the electric control box.

**Suitable cleaning tools and products**

**Cleaning method**

**ATTENTION** Do not use solvents that could damage the painted surface and synthetic materials. Specifically, do not use petrol gasoline, nitro thinners, perchloroethylene or trichloroethylene.

Parts to be cleane	Method and tools
Painted steel	Use warm water and food-friendly degreaser. Dry with a clean cloth.
Control panels	Clean with a soft dry cloth.
Electrical parts	Clean using a vacuum cleaner.

**Frequency of cleaning**

Frequency	Parts to be cleaned
Weekly	Control panels
Monthly	Motors
Monthly	Electrical components
Monthly	Steel structural work parts



## 6.2 Scheduled servicing

Any operation which can only be carried out by authorised personnel is considered scheduled servicing. It includes regular and preventative inspections and machine interventions carried out to ensure safe operation of the machine.

### **Qualifications of operator**

Scheduled servicing can only be carried out safely by trained and qualified personnel who know how to operate, set-up and service the machine and who have carefully read and understood the instructions and recommendations given in this section.

### **Regular inspections**

#### **Regular checks and adjustments**

<b>Name of parts to be checked and adjusted</b>	<b>Frequency</b>	<b>Method</b>
Emergency stop button	Every 40 working hours	Check the correct operation

#### **Regular controls and lubrication**

<b>Name of parts to inspect</b>	<b>Frequency</b>	<b>Procedure</b>
Chains and gearing	monthly	Grease
Jack	monthly	Grease



PLATON SERVICE  
8 (800) 500-3747  
www.platonservice.com

## Chapter 7 *Machine scrapping*

---

---

### 7.1 **Qualifications of operator**

Qualified mechanic who has read and understood *Fig. 1.1 Overall view of machine and Chapter 7 Machine scrapping*.

---

---

### 7.2 **Disconnecting the machine**

At the end of its technical and working life the machine has to be disconnected. Even though de-commissioning has taken place and the machine is no longer suited to the purpose for which it has been designed and built, it must still be possible to re-cycle the raw materials from which the machine was built.

---

**NOTE** The manufacturer will not be liable for any damage or injury to persons, animals or things caused by the re-use of individual parts of the machine for operations or assemblies other than those for which they were originally designed.

---

---

---

### 7.3 **Disconnection procedure**

---

**DANGER** The machine disconnecting and scrapping operations must only be carried out by trained and appropriately equipped personnel.

---

1. Switch off the machine, as described in *5.10 Switching off the machine* a pag. 26.
2. Disconnect all the power supplies. The power connections and the instructions for carrying out the operation are the same as described in *Chapter 4 Installation*.
  - a. Electric power supply. Disconnect the power supply cable from the terminal board of the electric control box.
3. Remove the following parts:
  - a. Electrical and electronic components.
  - b. Non-metallic parts and components.
4. If the machine is moved to another location, refer to *4.3 Transport* a pag. 18.

---

## 7.4 Residual risks after machine disconnection

Provided the instructions given in 7.2 *Disconnecting the machine* a pag. 30 have been followed carefully, there are no residual risks after the machine has been disconnected.

---

**ATTENTION** The materials used for building the machine are non-biodegradable. The machine must therefore be taken to an authorised scrap yard for disposal.

---



PLATON SERVICE

8 (800) 500-34-47

www.platonservice.com

## Chapter 8 *List of attached documentation*

---

Allegato 1 Spare parts

Allegato 2 Wiring diagram



**PLATON SERVICE**

8 (800) 500-34-47

[www.platonservice.com](http://www.platonservice.com)



**Spare parts catalogue**

SF. 500 base unit

<b>Ref</b>	<b>Description</b>
1	Extension for undertable
2	Undertable
3	Conveyor belt
4	Table
5	Waste drawer
6	Conveyor tightener cylinder
7	Fork for rolling pin
8	Spacer
9	Undertable locking handwheel
10	Conveyor supports
11	Electric box cover
12	Electric box
13	Structure
14	Adjustment foot
15	Food adjustment handwheel
16	Wheel
17	Wheel pin
18	Tie rod for conveyor
19	Motor bracket
20	Electric motor
21	Motor fulcrum pin
22	Motor pulley
23	Back side closing panel
24	Pedal
25	Pedal lever
26	Pedal operated microswitch for reverse motion
27	Conveyor fulcrum shaft
28	Pedal control guard
29	Front side closing panel

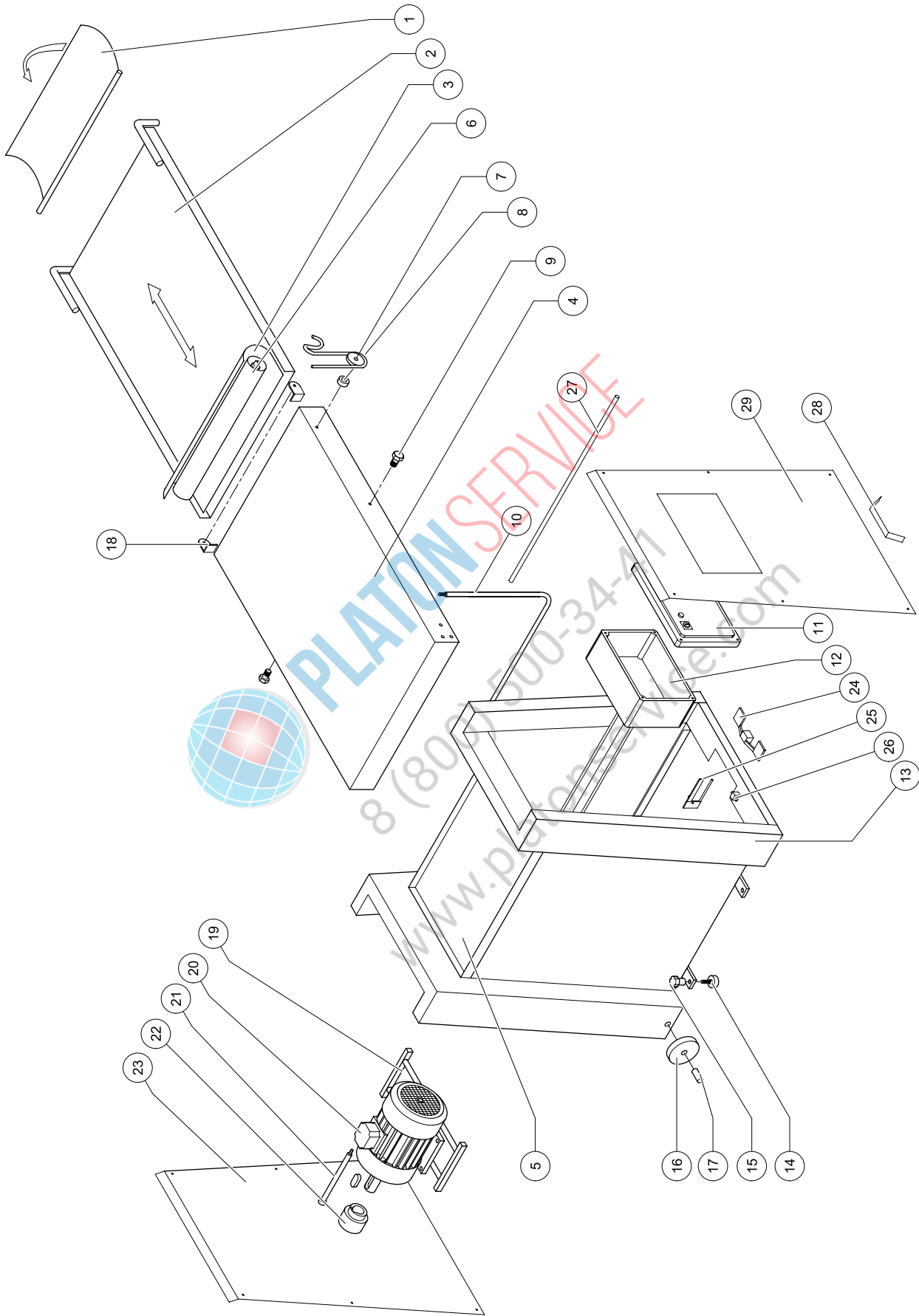

## SF. 500 head unit

Ref	Description
1	Right Hand Frame
2	Left Hand Frame
3	Right panel
4	Left panel
5	Flange
6	Bearing 6004 2RS
7	Circlip
8	Spacer
9	Free wheel Z=16 1/2" x 1/8"
10	Threaded pinion
11	Double-threaded screw
12	Double crown gear Z=16 1/2" x 1/8"
13	Washer
14	Spacer
15	Gasket
16	Bolt
17	Lifting rod
18	Roll shifting lever
19	Guard rod
20	Bushing
21	Right connecting rod
22	Top scraper shaft
23	Top scraper
24	Lifting shaft cover
25	Spacer
26	Tray support
27	Guard
28	Fixed roller
29	Bottom scraper
30	Bottom scraper tension spring
31	Sector gear for positioning scraper
32	Spacer
33	Pinion Z=16 3/8"
34	V belt A57
35	Pulley
36	Left connecting rod

Ref	Description
37	Flange
38	Lifting shaft
39	Shifting rod for connecting rod
40	Bearing brass
41	Handle return spring
42	Circlip
43	Bearing 6005 2RS
44	Chain tightener crown gear
45	Tie rod for chain
46	Lifting shaft bushing
47	Spacer
48	Guard closure microswitch
49	Rubber band
50	Microswitch plate
51	Manual reverse motion microswitch
52	Lever limit switch
53	Handwheel
54	Toothed sector
55	Handle
56	Lever for handle
57	Rubber band
58	Microswitch spacer
59	Manual reverse motion control rod
60	Manual control rod knob
61	Right conveyor pull cylinder
62	Left conveyor pull cylinder
63	Mobile cylinder
64	Double crown
65	Limit switch sector lever



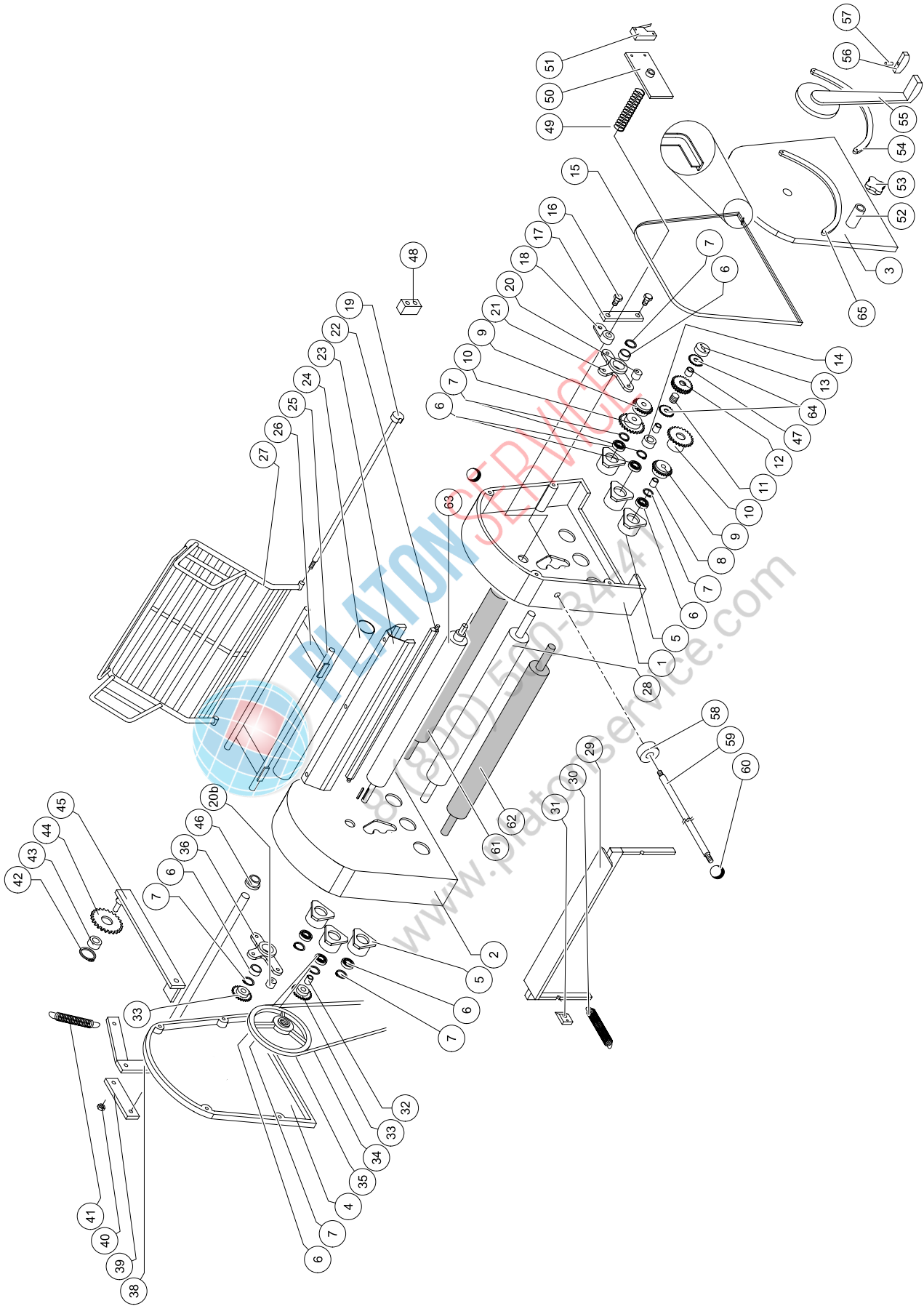

## SF. 600 base unit

Ref	Description
1	Extension for undertable
2	Undertable
3	Conveyor belt
4	Table
5	Waste drawer
6	Conveyor tightener cylinder
7	Fork for rolling pin
8	Spacer
9	Undertable locking handwheel
10	Belt drive cylinder
11	Table support
12	Electric box cover
13	Electric box
14	Structure
15	Adjustment foot
16	Adjustment foot handwheel
17	Wheel
18	Wheel pin
19	Tie rod for conveyor
20	Motor support
21	Electric motor
22	Motor fulcrum pin
23	Back side closing panel
24	Side panel cover
25	Table bracket
26	Table bracket
27	Bearing 6202 2RS
28	Electric motor
29	Pedale
30	Pedal operated microswitch for reverse motion
31	Clutch body
32	Disk made from braking material
33	Crown gear
34	Disk push washer
35	Rubber band
36	Pedal control guard
37	Front side closing panel

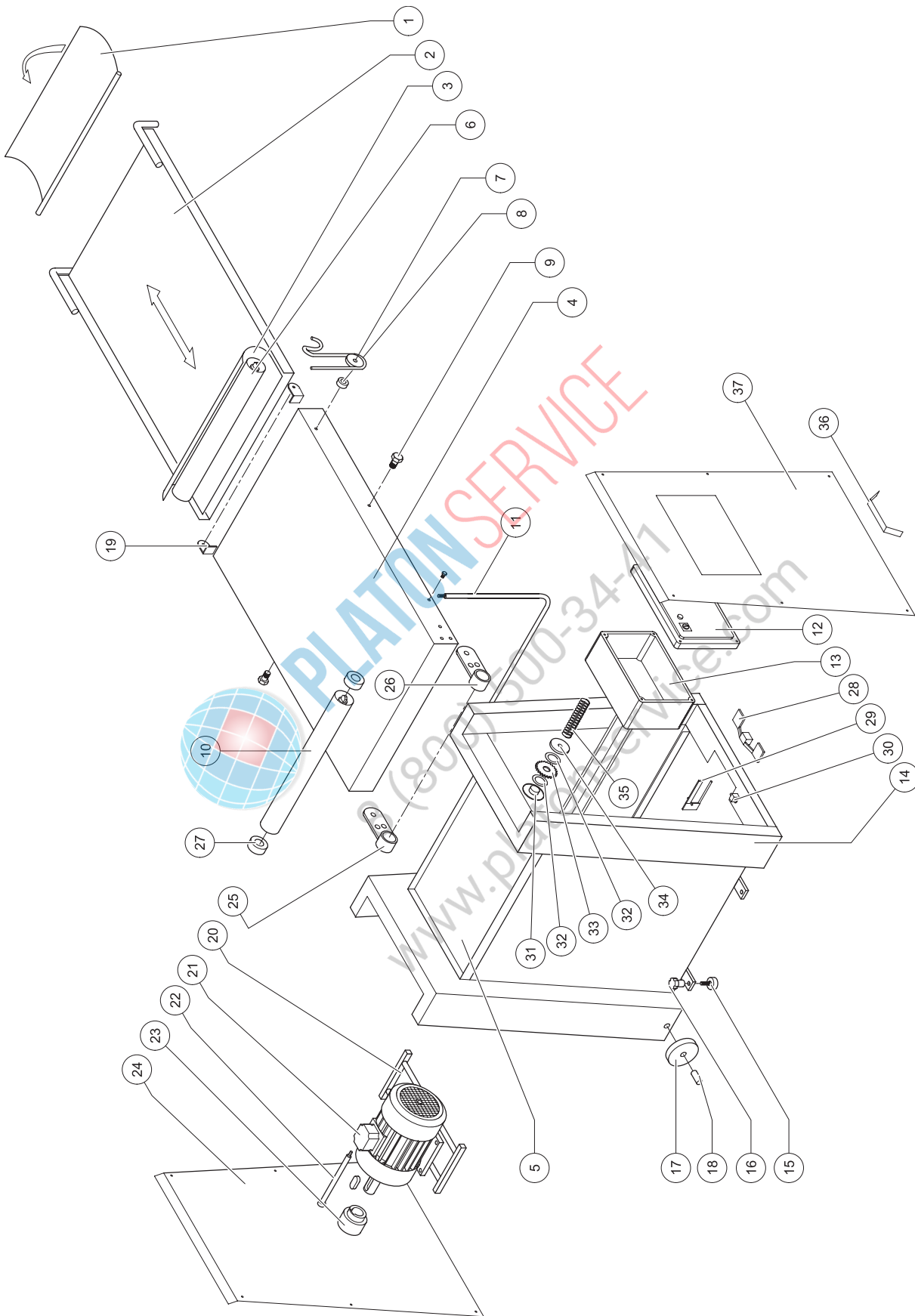

## SF. 600 head unit

Ref	Description	Ref	Description
1	Right Hand Frame	38	Pulley
2	Left Hand Frame	39	Left connecting rod
3	Right panel	40	Flange
4	Left panel	41	Lifting shaft
5	Flange	42	Lifting shaft
6	Bearing 6204 2RS	43	Brass
7	'Seeger' Ring	44	Rubber band
8	Spacer	45	Retaining ring
9	Freewheel Z=16 1/2" x 3/16"	46	Bearing 6005 2RS
10	Threaded pinion	47	Chain tightening crown
11	Double-threaded screw	48	Chain tightener
12	Double crown gear Z=18 1/2" x 3/16"	49	Bush
13	Washer	50	Bearing 3205 2RS
14	Spacer	51	Seeger ring
15	Gasket	52	Retaining ring
16	Bolt	53	Washer
17	Lifting rod	54	Rubber band
18	Shifting connecting rod	55	Pin
19	Guard rod	56	Spacer
20	Bushing	57	Spacer
20b	Eccentric bushing	58	Guard microswitch
21	Right connecting rod	59	Microswitch plate
22	Scraper shaft	60	Rubber band
23	Top scraper	61	Microswitch plate
24	Lifting shaft cover	62	Manual reverse motion microswitch
25	Spacer	63	Lever limit switch
26	Tray support	64	Handwheel
27	Guard	65	Sector gear
28	Flange	66	Handle
29	Drive shaft	67	Handle lever
30	Fixed roller	68	Rubber band
31	Movable roller	69	Microswitch spacer
32	Bottom scraper	70	Manual reverse motion control rod
33	Bottom scraper spring	71	Manual control rod knob
34	Sector gear for scraper positioning	72	Double crown Z= 15 1/2" x 3/15"
35	Spacer	73	Limit switch sector lever
36	Double pinion Z=17 3/8"		
37	V belt A 61		

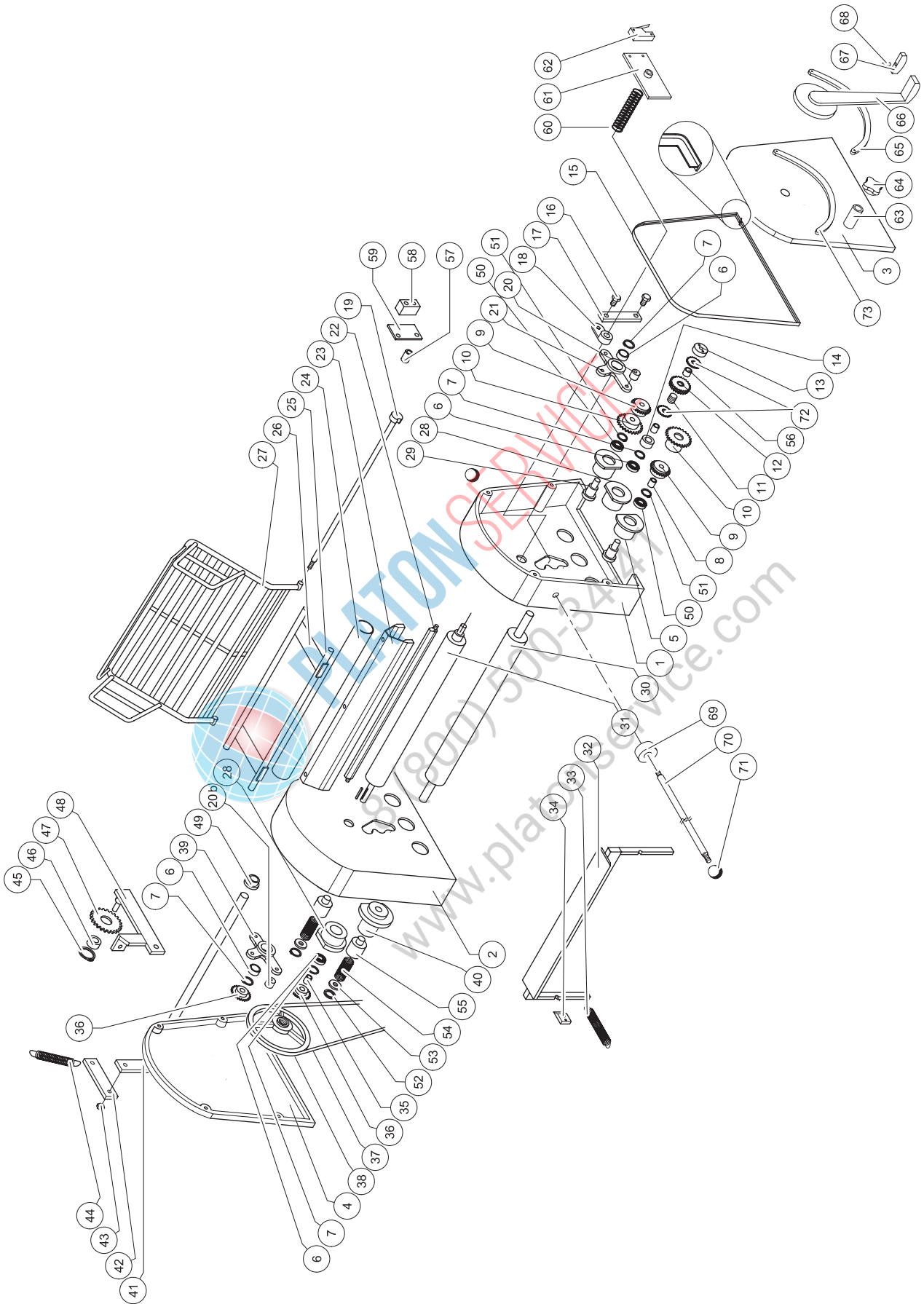

Schemi elettrici SF.500 - SF.600

A	B	C	D	E	F	G	H	I	J						
1	S	C	H	E	M	A	E	L	E	T	T	R	I	C	O
2	S	F	O	G	L	I	A	T	R	I	C	E			
3	M	O	N	O	F	A	S	E							
4	D	O	P	P	I	C	O	M	A	N	O				
5	C	O	N	S	C	H	E	D	A						

DESCRIZIONE IMPIANTO			NOTE : INTESTAZIONE						
DITTA: SFOMONES. PRG									
PROGETTO: 3/3									
FOGLIO: SFOMONES. 003									
DISEGNO: 15/01/104									
DATA:									



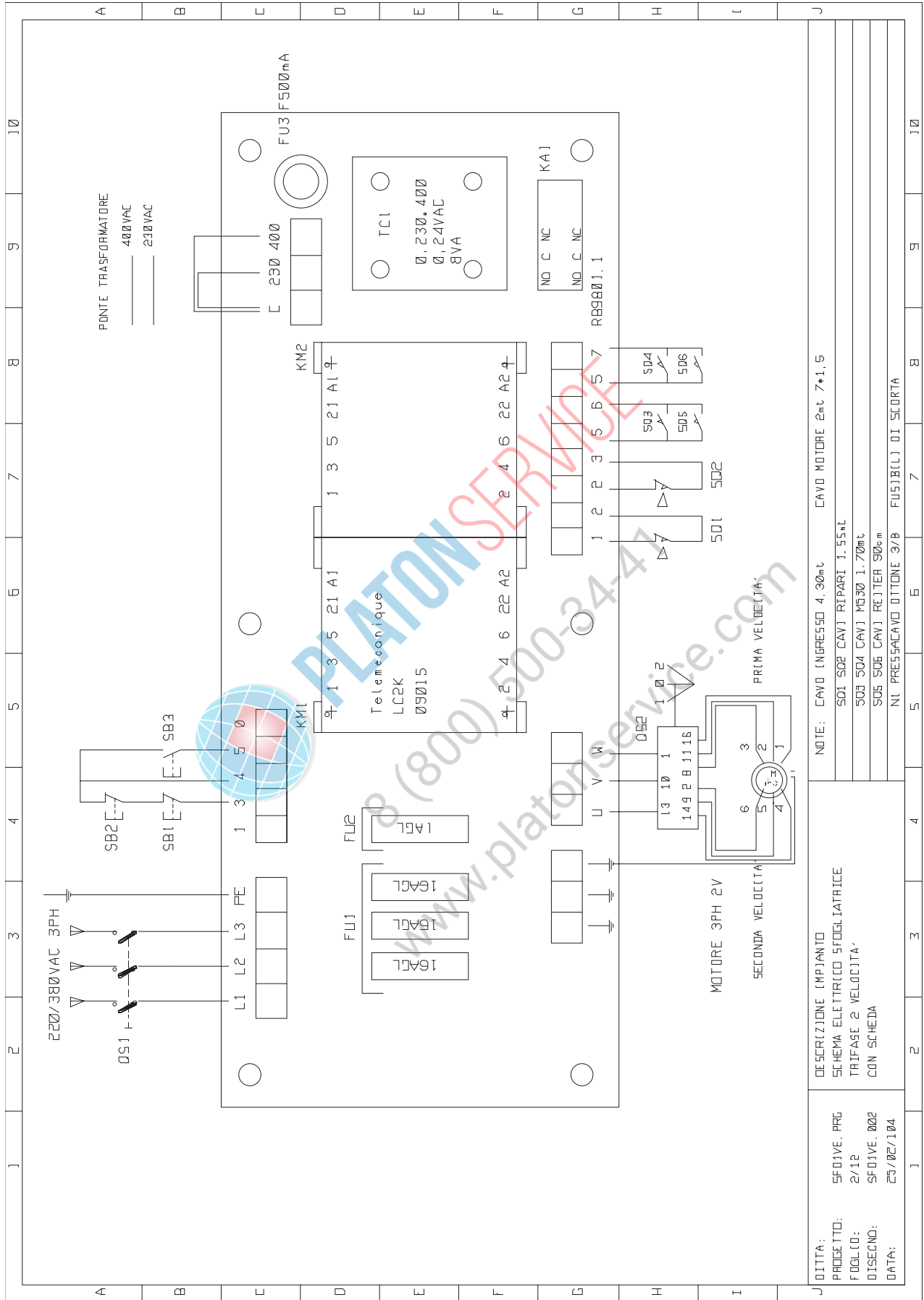

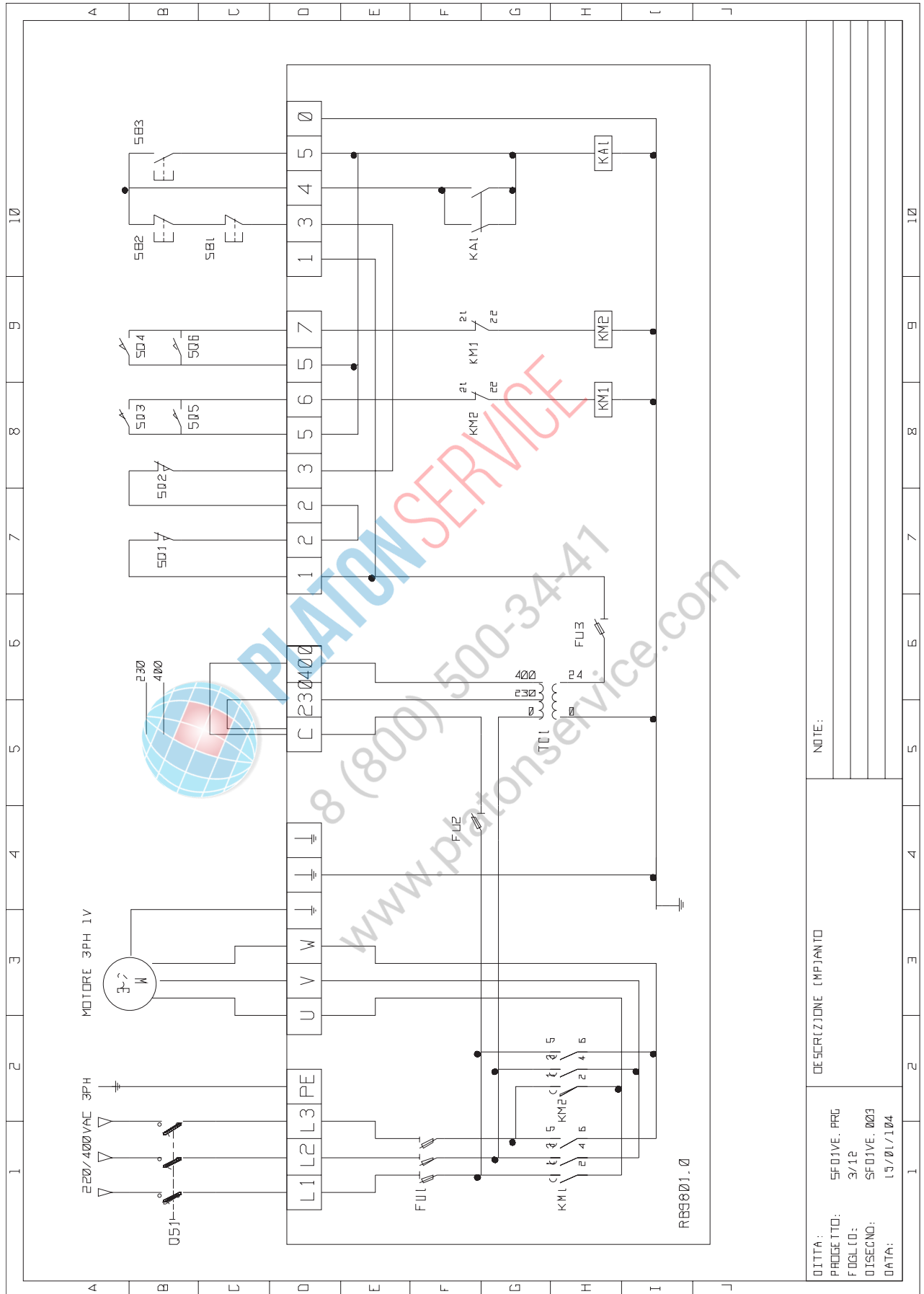
DITTA :		SFO1VE. PRG	
PROGETTO :		S/1P	
FOGLIO :		SFO1VE. 003	
DATA :		15/01/104	
DESCRIZIONE (MPJANTO)			
NOTE:			



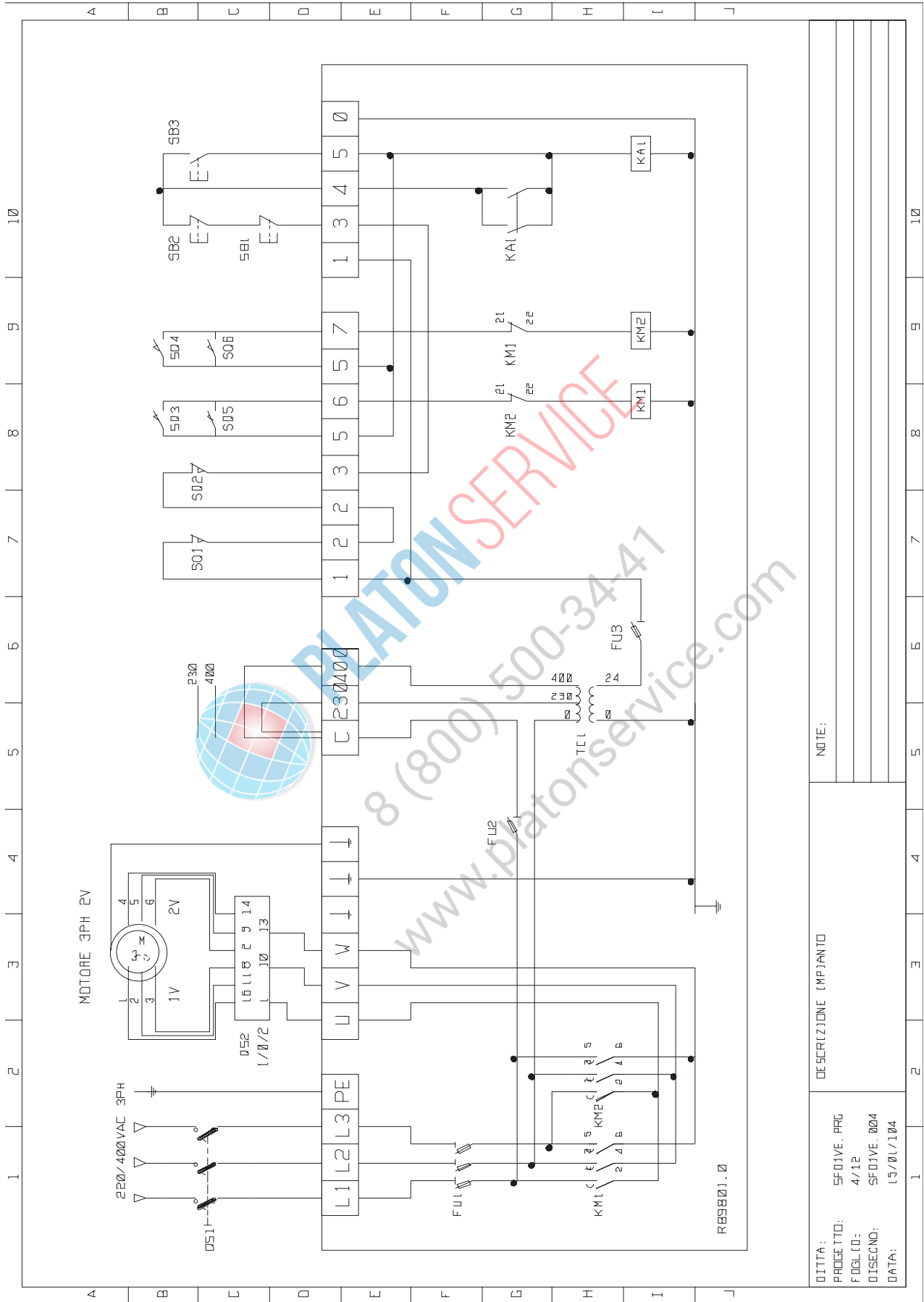

NOTE:

DESCRIZIONE IMPIANTO

DITTA : SF01VE. PRG  
 PROGETTO : 4/12  
 DISCEND : SF01VE. 004  
 DATA : 15/01/104

**DICHIARAZIONE DI CONFORMITÀ  
DECLARATION OF CONFORMITY  
DECLARACIÓN DE CONFORMIDAD  
DÉCLARATION DE CONFORMITÉ  
KONFORMITÄT SERKLÄRUNG**



Noi  
*We / El que suscribe /  
Nous / Wir*

**Dr. ZANOLLI s.r.l.**  
**Via Casa Quindici, 22**  
**37066 Caselle di Sommacampagna, VR**

dichiaro sotto la nostra esclusiva responsabilità che l'apparecchiatura  
*declare under our responsibility that the equipment / declara bajo su propia responsabilidad que el equipo /  
déclarons sous notre responsabilité que l'appareil / erklären in alleiniger Verantwortung, daß das Gerät*

**Marca**

*Manufactured by / Marca / Marque de fabrication / Bezeichnung*

**Modello**

*Model / Modelo / Model / Modell*

**N° di serie**

*Serial number / N° de serie / N° de série / Seriennummer*

**Anno di costruzione**

*Year of construction / Año de construcción / Année de construction / Baujahr*

come descritto nella documentazione allegata, è in conformità con le seguenti direttive europee  
*is in conformity with the following European Directives / es conforme con las siguientes Directivas europeas /  
est conforme aux suivantes Directives européennes / auf das sich diese Erklärung bezieht, mit den E - Normen*

**- 2014/35/CE Direttiva Bassa Tensione**

*Low Tension Directive / Directiva Baja Tension / Directive Basse Tension / Niederspannungsrichtlinie*

**- 2014/30/CE Direttiva Compatibilità Elettromagnetica**

*Electromagnetic Compatibility Directive / Directiva Compatibilidad Electromagnetica /  
Directive Compatibilité Electromagnétique / Elektromagnetische Verträglichkeit*

**- 2006/42/CE Direttiva Macchine**

*Machines Directive / Directiva Maquinas / Directive Machines / Maschinenrichtlinie*

**- 1935/2004/CE Regolamento Oggetti destinati a venire in Contatto con i Prodotti Alimentari**

*Regulation for Equipment intended to come into Contact with Foodstuffs / Normativa para Equipos destinados a  
entrar en Contacto con Alimentos / Réglementation Objets destinés à venir en Contact avec des Produits  
Alimentaires / Gesetzliche Regelung der Gegenstände, die mit Lebensmitteln in Kontakt kommen*

**e con le norme cogenti alle direttive.**

*and with the compulsory regulations of the Directives / y con las normas ineludibles de las Directivas /  
et aux normes inéluctables des Directives / und mit den Zwangsvorschriften der Richtlinien, übereinstimmt*

Caselle di Sommacampagna

**Dr. Zanolli s.r.l.**  
**Collaudatore**  
*Tester / Ensayador / Testateur / Prüfer*

Dr. Zanoli s.r.l.  
Via Casa Quindici, 22  
37066 Caselle di Sommacampagna VR  
Tel. +39-0458581500 Fax +39-0458581455  
VAT N.IT00213620230



PLATONSERVICE  
8 (800) 500 000

www.platonservice.com